

# DB5 PARTS

PART No: **037-A**  
**SUPPORT ROD**

The parts supplied with this issue help to build up the front section, with the bonnet's support rod – or bracing rod – and the radiator section. They will all be concealed inside the model.

## PART LOCATION

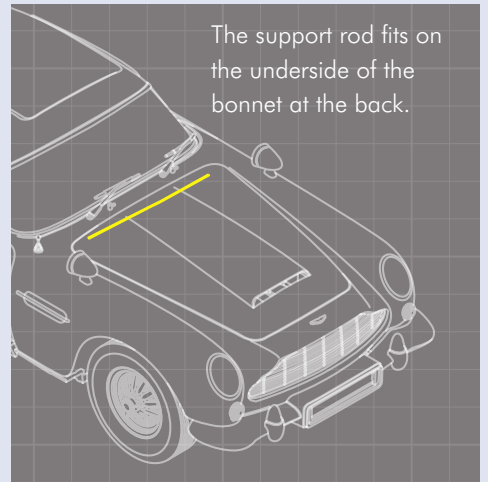

## ASSEMBLY INSTRUCTIONS

Clip the support rod (037-A) to the underside of the bonnet. The middle fits into the support rod holder and the ends of the rod fit into the grooves on the bonnet.

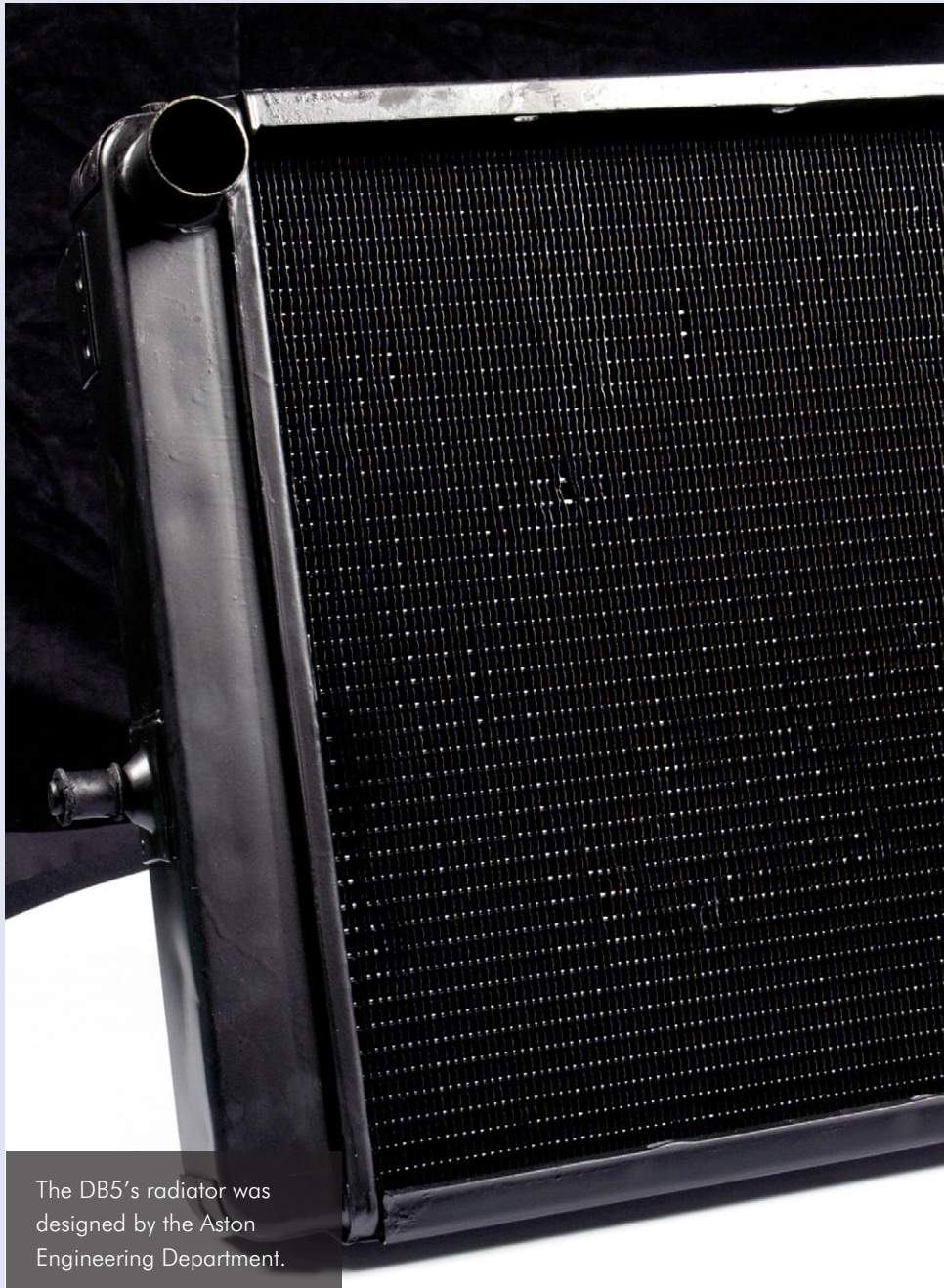
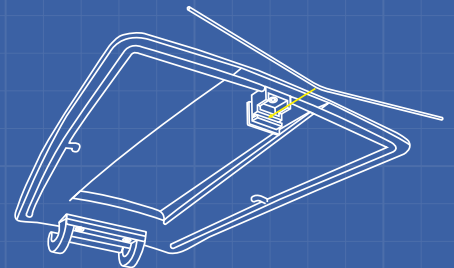

The DB5's radiator was designed by the Aston Engineering Department.

Visit the website:  
[www.007DB5.com](http://www.007DB5.com)  
for complete instructions on building your model DB5

## PART No: 037-B, 037-C RADIATOR FRONT & REAR

### PART LOCATION

The radiator section sits behind the front bumper. From the inside it will connect to the car's front body.

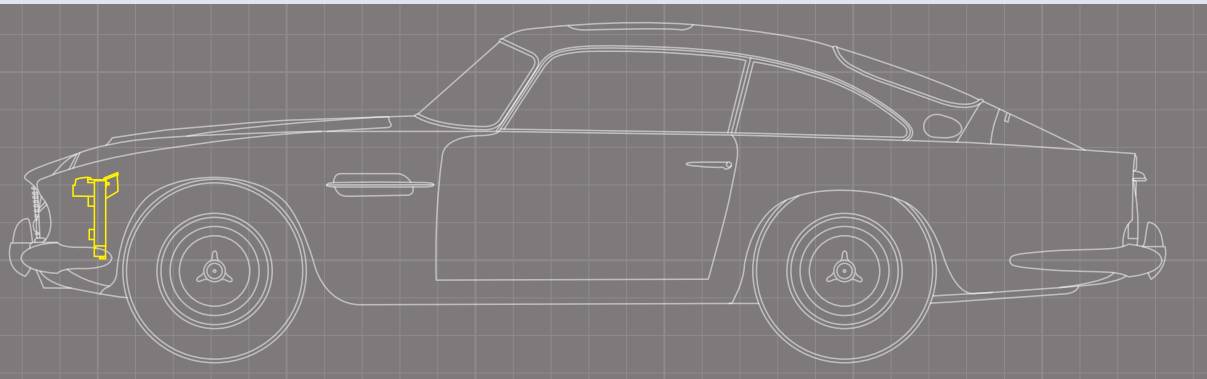

### ASSEMBLY INSTRUCTIONS

Clip the radiator front and the radiator rear to one another using your fingers to push them together so the fit is as tight as possible.

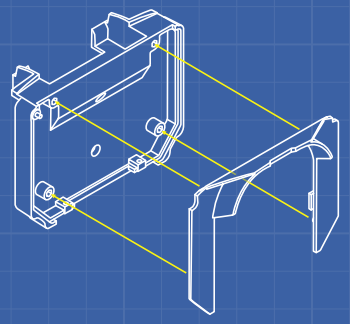

### THE REAL DB5



The cooling system had a cooling capacity of 28 pints.

## PART No: 037-D WATER TANK PART

### PART LOCATION

The water tank part, or lower radiator cowl, sits on the back of the radiator.

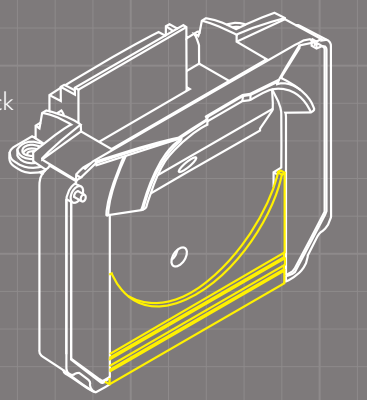

### ASSEMBLY INSTRUCTIONS

This is one of the last parts that you will fit to the model. It fits to the back of the radiator when the car is completely assembled.

